

Towards Integration Driven Design Experience Report

Stephan Jacobs
Aachen University of Applied Sciences
jacobs@fh-aachen.de

Abstract: Despite the fact, that testing and integration belong to the most critical and time consuming activities especially in big software development projects, most projects are still driven by design. This has several impacts on the integration activities. The following paper describes an approach which has been used successfully at Ericsson in the telecommunications industry. As integration of the different components is regarded as the most tricky activity, the whole project is driven from the integration perspective. This impacts the organization, the scheduling, and the interfaces between design and integration. The paper describes the experiences when setting up an integration driven project.

1 Introduction

The development of the GPRS and the UMTS networks has been a big challenge for all competitors in the telecommunications industry. One of the problems has been – and still is – the size and the complexity of the complete network and of each individual switch or node. There are strong requirements on all nodes and on the complete network with respect to performance, stability, and robustness. Dependent on the different organizational backgrounds, different strategies have been taken by the various companies, who participated in this competition. One of the companies, taking the race was Ericsson. From the perspective of development, Ericsson's background can be described as follows: The development sites of Ericsson are literally spread around the world.

Based on the experiences from other network development activities before (GSM, earlier releases of GPRS), the following guiding principles were decided about:

- It is not possible to develop the whole network in one big step. Vice versa, the best and only chance to get it to run is to split the development in several pieces, which are designed, coded, integrated, and verified step by step.
- Integration of the individual nodes is the most critical step during development. Integration is a bottleneck in the complete development process. Integration is hardly predictable. If integration does not succeed, functional testing and verification is blocked.

Based on these principles, a process similar to Test Driven Development (TDD) [Be02, We05] was specified. Whereas TDD most often has small development teams in mind, the Ericsson approach “Integration Driven Design” is much larger in scale to fit to the given situation. This approach has implications on scheduling, organization and the interfaces between design and integration.

2 Integration Driven Design: Setting Up the Project

There are two principal approaches to integration: The first one goes back to the waterfall-model of software engineering. The system's architecture divides the system into several components. These components are completely developed before putting together. Once all components are delivered, integration takes place in one big step (or big bang). This approach is based on the assumption, that interfaces are specified precisely enough, to plug together all components without bigger problems. The second approach is oriented towards continuous development approaches. The components are developed step by step. After each step, already existing parts are delivered and integrated. This requires additional coordination as the individual steps for each component have to be aligned. In contrast to the first approach, this stepwise integration has several advantages:

- The integration steps are now smaller and thus easier manageable. Problems are thus easier to identify, to locate, and to fix (cf. to daily build [CuSe 97]).
- In the big bang strategy, the quality level goes often down to a level, where the whole system does not work anymore. This has implications not only for integration but for other activities as well. Using the stepwise integration strategy, a certain level of quality is always available, verification activities can start earlier.
- Going for the big bang strategy, there is hardly any transparency in progress from a project management perspective. Sometimes it takes days, sometimes it takes weeks to get the system back to a basic quality level.
- A higher degree of parallelism between design and integration and verification can be achieved. Verification of those parts developed in step one, integration of the parts developed in step two and design of parts in step three can run in parallel.

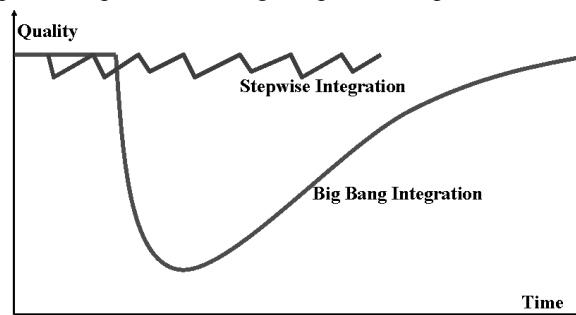

Figure 1 : Big Bang versus Stepwise Integration

2.1 Change of perspective

As explained above, stepwise integration requires additional coordination, to get all components at the right time. An integration plan is necessary, the development projects have to align their plans with this central integration plan. Going for a stepwise approach moves the focus from design and coding to integration. The perspective changes from design to integration. In the following, this is elaborated in more detail.

The design driven and the integration driven processes are shown in the following table:

Design Driven Project	Integration Driven Project
Specification of key dates and features	Specification of key dates and features Ranking of features from an integration perspective, proposal of delivery dates
Distribution of features to node projects	Distribution of features and delivery dates to node projects
Proposal of timeplan by each node project	Proposal of timeplan by each node project
Composition of master time plan	Composition of master time plan

In design driven projects, the integration and test project comes at the very end and has to derive their plan from the master time plan. In integration-driven projects, there is an additional step: Features are ranked from an integration driven perspective and tagged with requested delivery dates. The position of integration has changed. In the new process, integration is in a role to specify requirements early, to act rather than react, to offensively propose schedules rather than argue against impossible dates. Even if this sounds just like two alternative processes, it is much more: It is a cultural shift! The responsibility and authority to act and to give the project's pace is moved from design to integration. This has impacts on people and politics. Thus, this step has to be carefully prepared and thoroughly communicated.

2.2 Organization

To bring the integration project into a different role and give some formal power to it requires some changes compared to typical project organizations. First, integration has to be a project of it's own, to be recognizable. Second, the responsible project manager for integration has to be lifted within the total project hierarchy. Taking integration driven design seriously, it requires to put integration into a leading role in the organization as well. The project manager for integration and verification is now in double role. First, as before he has to organize and run the integration and verification (I&V) project. In addition, he is responsible to specify an I&V strategy which has to be followed by all node projects. This includes the proposal of a timeplan from an integration perspective, the definition of the quality level expected after each phase in the project both within the node project and within the I&V project.

2.3 Integration Anatomy

Each project needs a focus point, this is especially true for huge projects. It has to be understandable for each and everybody, how the big picture looks like and how the own work fits into this picture. In the Ericsson project, this focus point was the "Integration Anatomy". The integration anatomy is a very high-level, abstract master time plan, which can be easily understood and maintained. The following figure shows a typical integration anatomy.

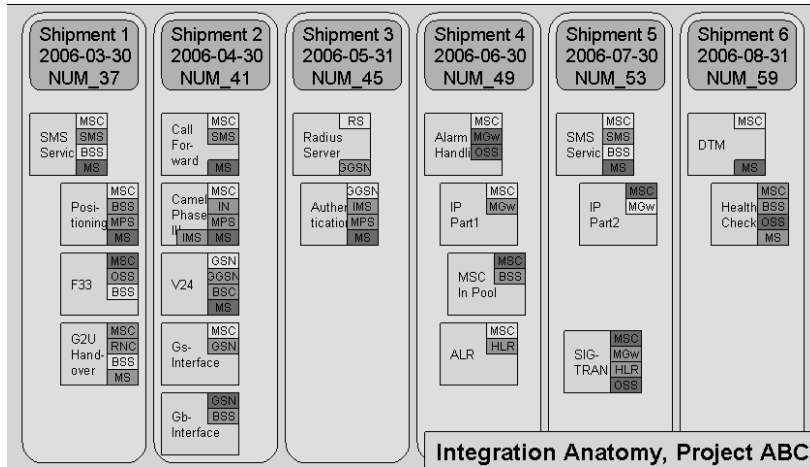

Figure 2 : Integration Anatomy

The integration anatomy subdivides the design in so called “shipments”. In Figure 2 the shipments are shown as the vertical rectangles. In the top of each shipment, the rectangular shows more detailed information about the shipment: The shipment number, the ready date, and a version number. At the ready date of the shipment, the design organizations have to deliver (ship) those parts which have been agreed on earlier. The integration project, the receiving partner, starts at this date to put together all deliveries, i.e. all single nodes. In the best case, all integration work is done until the next shipment date. Each of the small squares in the anatomy represents one feature. For each feature, not only the feature’s name but also the nodes, which have to deliver functionality, are given. The nodes are represented with a colour, which shows the current status of the feature (green: under control, yellow: slightly delayed but solveable, red: delayed).

When building up the anatomy, the strategy from an integration point of view is to get the tricky features in the early shipments. Another goal is to avoid too many features in the last shipments. If there are too many features at the same point in time, we talk about big bang integration. In the Ericsson project, our real anatomy included roughly 100 features. To make the anatomy really visible to everybody, it was printed in A1 format and pinned at central places like coffee corners, meeting rooms etc.

2.4 Negotiations between Development Projects and Integration Responsibility

At the very beginning of the project, the integration and the design projects have negotiations about the schedule, the overall I&V-strategy and the expected level of quality. The results of the scheduling are placed into the integration anatomy.

At Ericsson, the goal of the I&V-strategy was, to clarify, who is doing what, to neither do double-work nor let any tests fall between the chairs. At this early time, expectations from both sides were given to the other project. Requests by the integration project included a certain level of quality described in terms of testcases.

Although, most of the requests by the integration project seemed to be obvious, experience in the past had shown, that even these obvious requirements have to be explicitly stated especially, if node projects were not used to continuous deliveries within a project. These projects tended to move documentation work and quality assurance activities to the last shipment. It had to be made explicit, that integration and verification required basic documentation and basic level of quality already for the first shipments.

Comparing the experiences between past projects and the last ones, integration driven design emphasise the importance of early agreements: First, because at the very beginning of the project, all sides have less stress, they are better able to understand the position of the other parties. Second, all expectations should be clear as early as possible. Experience shows as well, that if projects are running under pressure, then negotiations are tough, even if obvious issues are asked for.

2.5 Interworking-Agreement and Ready-for-Integration-Checklists

In the Ericsson project, the following approach was taken to document agreements and mutual expectations. Two special type of documents were prepared: Interworking Agreement and Ready-for-Integration-Checklists: The interworking agreement was the basic document to describe the way of cooperation between the design and the I&V project. Both documents are still used today.

The Interworking Agreement is split up into the following parts:

- The principles of cooperation like the software anatomy, the shipments etc.
- Testcases which should be executed at the node project on behalf of the integration project and vice versa. Documents, which should be co-inspected by the other side.
- Processes like correction handling, escalation procedures and patch handling
- Performance indicators like answer- and correction-time for corrections

The Ready-for-Integration-Checklist is agreed on at the same time as the Interworking Agreement. Once the checklist is agreed on, it's used for each delivery as a template. The checklist contains quality indicators which assure a certain level of quality (like the smoke test for daily builds). Quality indicators can be certain testcases or measurements like "system runs stable in idle mode for more than one hour" or "system can handle at least ten users in parallel".

3 Integration Driven Design: Running the Project

Once, the integration-driven project is set up, the job is not done. It is necessary to still fight for the I&V perspective, until the project is finished. However, the focus of this paper is on **setting up** the project. Thus, the weekly anatomy meeting to keep the integration anatomy up to date and the delivery meetings to check the quality of each shipments are only mentioned but not discussed in detail.

4 Experiences

Comparing integration driven projects with former projects, the following experiences have been made:

- Breaking up a project into several shipments reduces the leadtime of the overall project and especially the effort for integration. To split the integration into smaller pieces gives a much bigger chance for success.
- Delivering several shipments is a cultural shift and requires careful preparation, control and support – especially in the first project. Programmers tend to deliver the current state of their work neglecting documentation and quality assurance. This is only planned for the final delivery. If projects are under pressure – and projects are always under pressure – the documentation and quality gets lower priority, thus ...
- ... it is important to agree in the early phases of a project on mutual expectations. These expectations have to be documented explicitly. Experience shows, that negotiations about these expectations are relatively easy to achieve in the very beginning of a project and – vice versa – mostly impossible to achieve, once the project gets late and under pressure.
- Big projects require a few focal points, which enable everybody, to identify where he is. The integration anatomy is such a focal point. It's easy to understand, it contains a lot of information, it shows how the single parts are connected together from a scheduling point of view. However, the anatomy is only taken seriously if it's up to date. This requires constant planning work.

5 Summary

The approach used by Ericsson to develop big telecommunication networks has been sketched. It has been shown, that especially for these big and complex projects integration driven design is a much better strategy, then the ones used in the former projects. Integration-driven design requires a change in organization, a focus on the integration plan and clear agreements about the content, timing and quality of early deliveries. Integration driven design is a cultural shift. Consequently, it requires lots of communication, it takes time before acceptance and needs support by senior management.

6 References

- [Be02] Kent Beck, "Test Driven Development", Addison-Wesley, 2002
[CuSe97] Michael A. Cusumano, Richard W. Selby, "Microsoft Secrets", Touchstone, 1995
[KSE01] A.Ragnar Kling, Charlotta Svensson, Mats Engwall, "Project Management Models in Practise", Working Paper, FENIX Centre for Innovations in Management, 2001, <http://www.fenix.chalmers.se/publications/2001/pdf/WP%202001-19.pdf>
[Mc95] Jim McCarthy, "Dynaics of Software Development", Mircosoft Press 1995
[We05] Frank Westphal, "Testgetriebene Entwicklung mit Junit & FIT", dpunkt Verlag, 2005